

Milk from Cow to You!

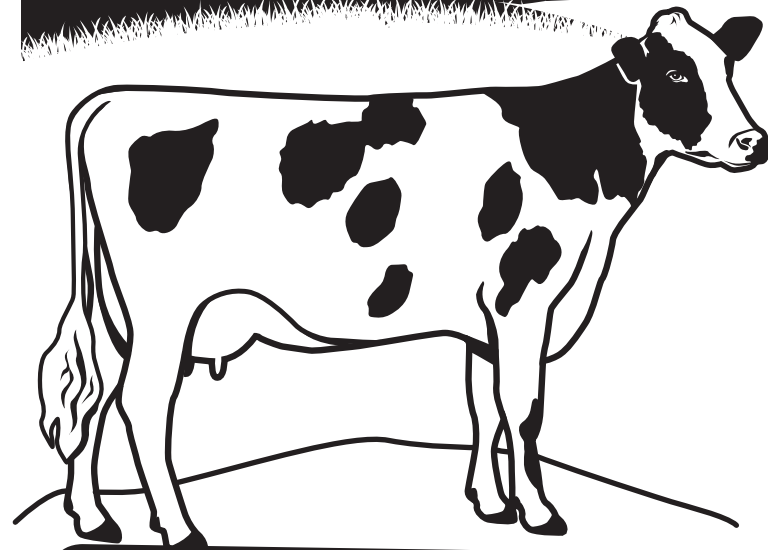

1. Milk comes from healthy, well-fed cows that are raised on dairy farms.



2. To begin milking, a cow's udder is washed before the milking machine is attached. This happens at least two times a day.

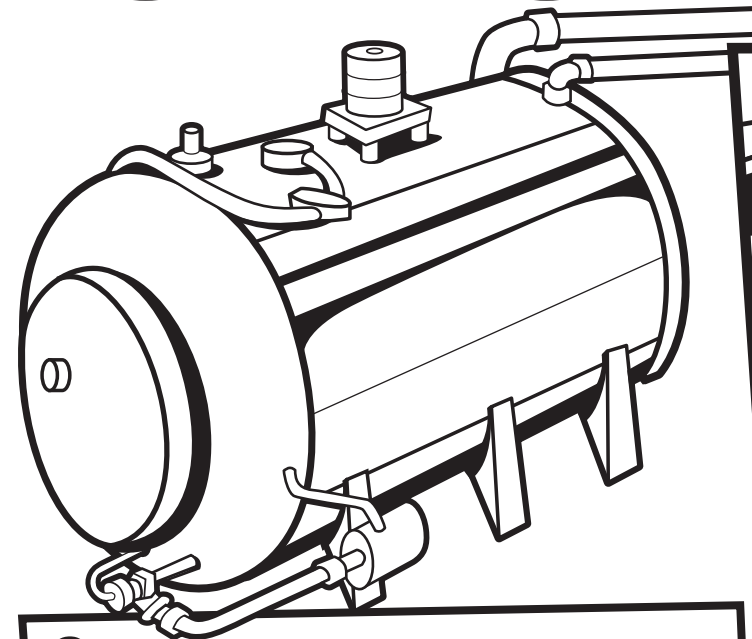

3. Fresh milk from the cow is pumped through a pipe and into an insulated tank, where it is cooled and kept fresh and safe.

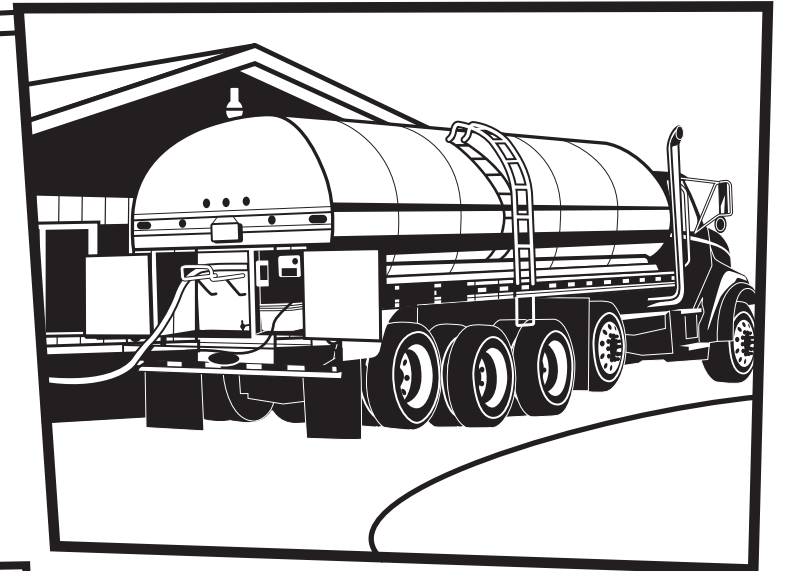

4. Each day, a special insulated tanker truck comes to the farm to pick up the cold milk and deliver it to the dairy plant.

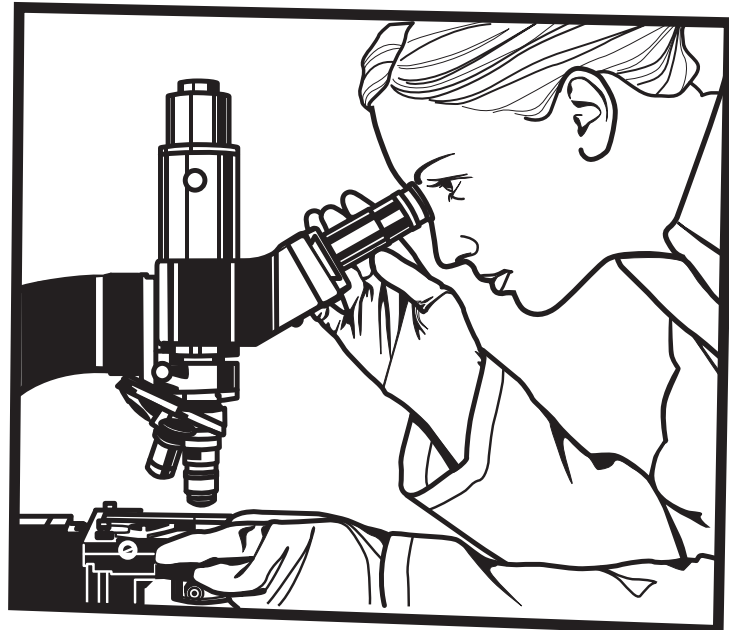

5. At the dairy plant, the milk is kept cold and tested many times for quality.

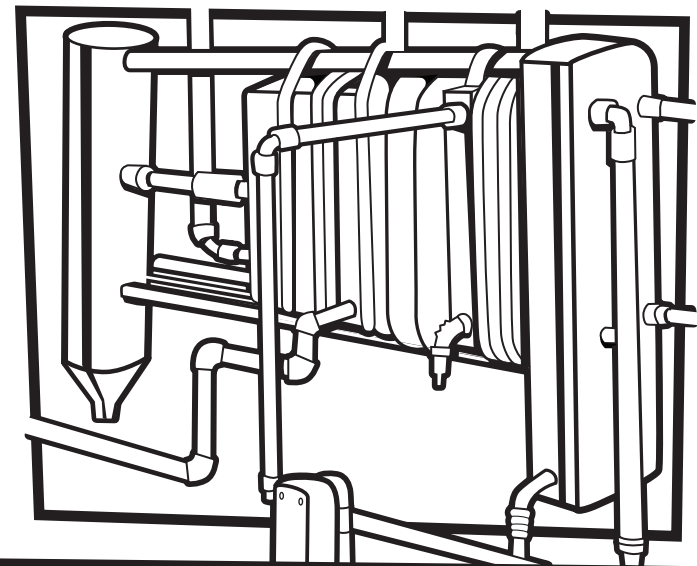

6. Next, the milk is quickly heated, or pasteurized. This is an important step to ensure the milk is safe and wholesome.

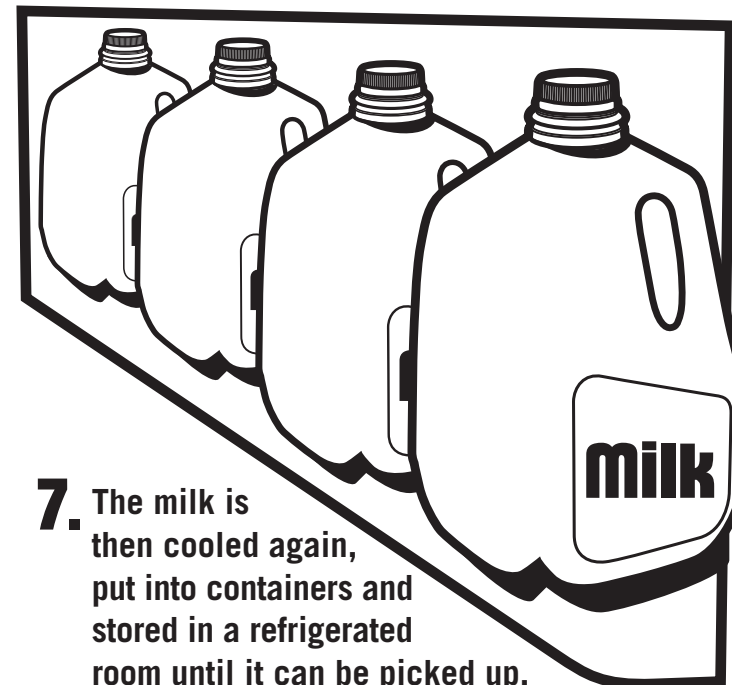

7. The milk is then cooled again, put into containers and stored in a refrigerated room until it can be picked up.



8. Within two days after milking, the milk is loaded onto refrigerated trucks and delivered to schools, restaurants and supermarkets.